

DIMENSIONS 400-001 // 410-001
400-003 // 410-003
400-006 // 410-006

SERIES 400
410

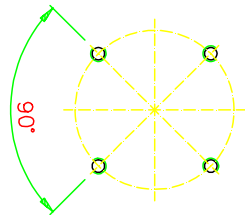
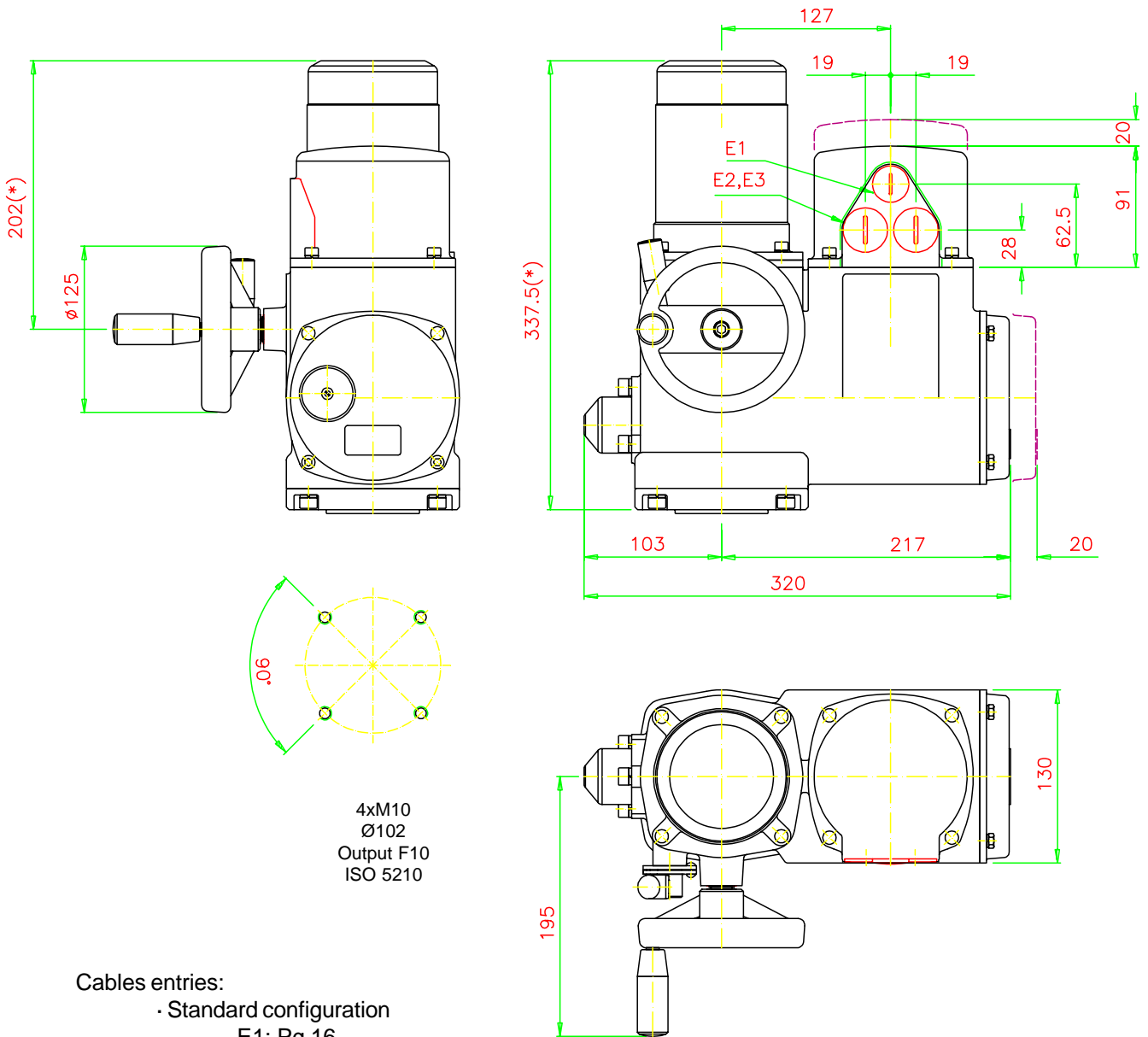

4xM10
 Ø102
 Output F10
 ISO 5210

Cables entries:

- Standard configuration
 E1: Pg 16
 E2,E3: Pg 21
- Option NPT:
 E1: 1/2" NPT
 E2,E3: 3/4" NPT
- Option metric:
 E1: M20x1,5
 E2,E3: M25x1,5

Dimensions in mm.

(*) Exact dimensions depending on motor required.

Approximate weight : 22 (Kg.).

Subject to change without notice. Previous data sheets invalid with the issue of the latest data sheets.

VALVE CONTROL



N° :

E1400A020

Issued:

06.02