

LINEAR THRUST UNIT DIMENSIONS

SERIES	400.	410.
	40B.	41B.
	4H0.	4P0.

Linear Thrust unit LC 12

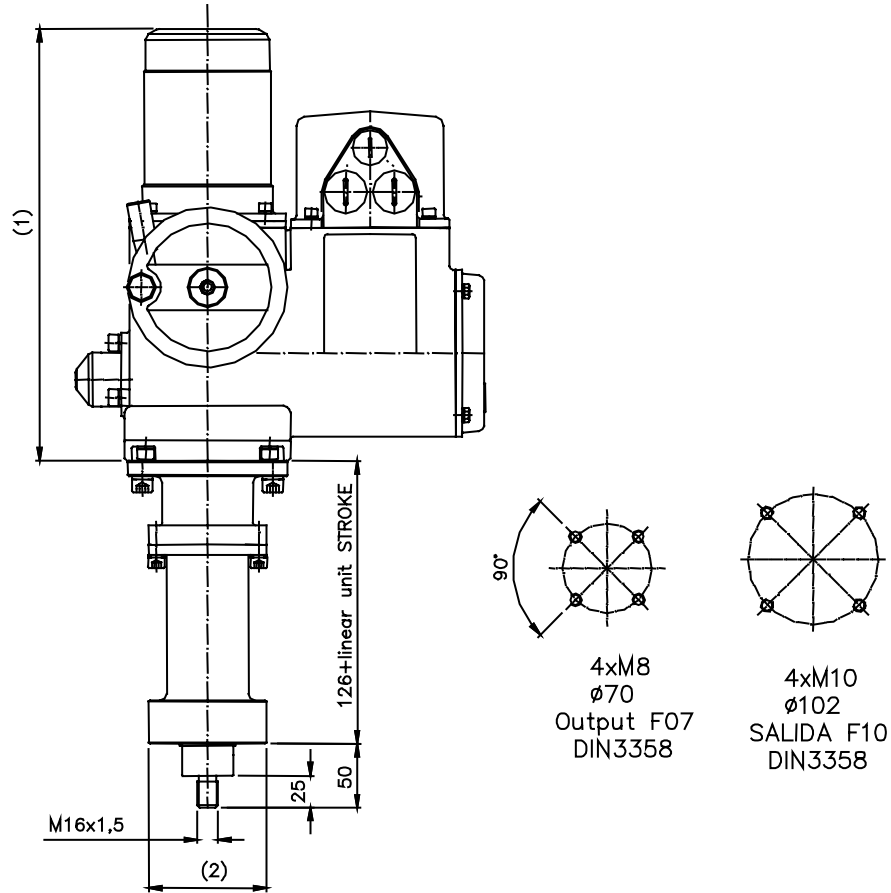

NOTES:

- 1) Actuator dimensions depends on model (Series) and size, see suitable CENTORK electric actuators technical sheet.
- 2) Dimension depends on Output flange size.
- 3) Dimension depends on linear thrust unit stroke.

Instead of valve mounting flange, the linear thrust unit can be mounted on a base support. For further information, contact Centork Valve Control S.L.

VALVE
CONTROL



N° :

E1400X201

Revision:

04.05