

DIMENSIONS
510-011

510 SERIES

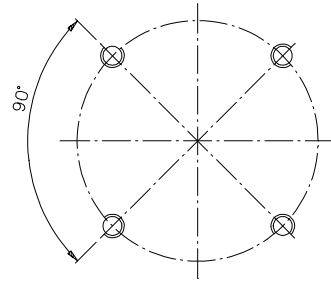
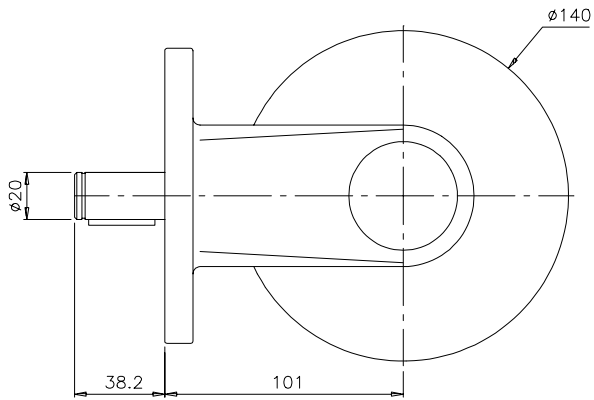
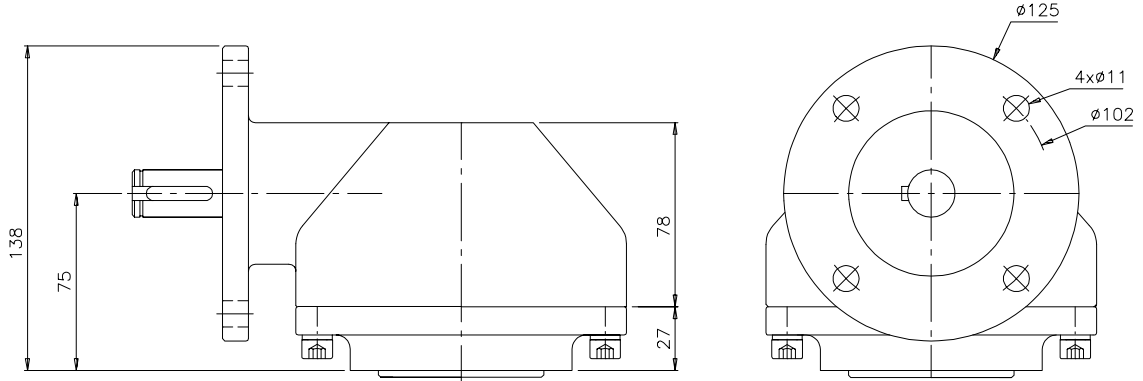

4xM10
Ø102
Output F10
ISO 5210

Dimensions in mm.

Approximate weight: 14 (kgs.)

Subject to change without notice. Previous data sheets invalid with the issue of the latest data sheets.

VALVE
CONTROL



N° :

E1510X023

Issued:

10.01