



STAINLESS STEEL VALVES

GENEBRE PART: 2529 2 PCE FULL BORE BALL VALVE FLANGED PN40 (DIRECT MOUNT)



SPECIFICATIONS

1	Material SS 316 CF8M
2	Ends according to DIN 2501 PN40
3	Max working pressure 40 BAR (See P x T chart below)
4	Max Temperature -30°C to +180°C
5	Full bore
6	Anti-static device, fire-safe design
7	R PTFE seats, PTFE & graphite seals, + Viton stem O ring.
8	Belville washer securing stem nut protected by lock washer
9	Direct mount ISO5211 patent 9900474 respected

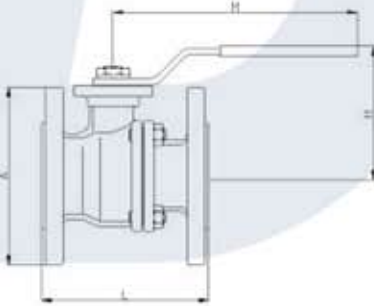

DIMENSIONS

AVOL REF	SIZE mm	L mm	H Mm	ISO5211 / stem	Torque Nm *	Wt Kg
2529 10	2 1/2"	170	180	F07/10 x 17	36	17.15
2529 11	3"	180	180	F07/10 x 17	60	21.20
2529 12	4"	190	184	F07/10 x 17	95	29.90
2529 13	5"	325	235	F10/12 x 27	150	52.90
2529 14	6"	350	250	F10/12 x 27	210	75.45

* Torque is without safety.

PRESSURE/ TEMPERATURE CHART

