

GATE VALVES

SÜRGÜLÜ VANA



standard features

- **Description** ROUND BODY
BOLTED BONNET
OUTSIDE SCREW AND YOKE
RISING STEM
NON RISING HANDWHEEL
FLEXIBLE WEDGE
RENEWABLE SEATS
- **Design** DIN 3352
DIN 3840
- **Face to face** DIN 3202
- **Flanges** DIN 2501
DIN 2547
DIN 2526 FORM E
BW TO DIN 3239
- **Testing** DIN 3352 Part 1
DIN 3230 Part 3
- **Rating** DIN 2401
- **Marking** EN 19
CE - PED
- **Certificates** EN 10204 – 3.1 B

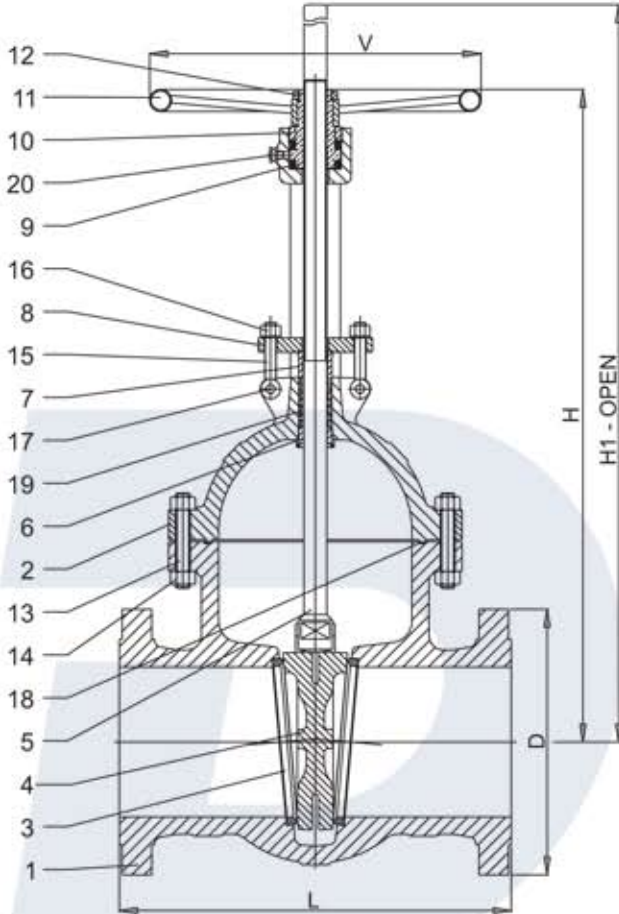

THE USE OF GEAR OPERATOR IS RECOMMENDED
STARTING FROM THE FOLLOWING DN/PN

DN	500	400	300	200	200	150
PN	16	25	40	63	100	160

PART NAME	A12xx	C12xx	FH12xx	FK12xx
1 Body	1.0619	1.7365	1.4552	1.4581
2 Bonnet	1.0619	1.7365	1.4552	1.4581
3 Seat ring surface	X20Cr13 (1)	X20Cr13 + HF (1)	X6CrNiTi18-10 (1)	X5CrNiMo17-12-2 (1)
4 Wedge seat surfaces	X20Cr13 (2)	X20Cr13 + HF (2)	X6CrNiTi18-10 (2)	X5CrNiMo17-12-2 (2)
5 Stem	X20Cr13 (3)	X20Cr13 (3)	X6CrNiTi18-10 (3)	X5CrNiMo17-12-2 (3)
6 Back seat	X20Cr13 (3)	X20Cr13 (3)	X6CrNiTi18-10 (3)	X5CrNiMo17-12-2 (3)
7 Gland	X20Cr13 (3)	X20Cr13 (3)	X6CrNiTi18-10 (3)	X5CrNiMo17-12-2 (3)
8 Gland flange	1.0460	X5CrNiMo17-12-2	X6CrNiTi18-10	X5CrNiMo17-12-2
9 Yoke sleeve	MS58 (4)	MS58 (4)	MS58 (4)	MS58 (4)
10 Yoke nut	1.0460	1.0460	X6CrNiTi18-10	X5CrNiMo17-12-2
11 Handwheel		← Steel →		
12 Handwheel nut	1.0460	1.0460	X6CrNiTi18-10	X5CrNiMo17-12-2
13 Bolts	CK35	21CrMoV57	A2-70	A2-70
14 Nuts	C35	24CrMo5	A2-70	A2-70
15 Eye bolts	CK35	24CrMo5	A2-70	A2-70
16 Nuts	C35	24CrMo5	A2-70	A2-70
17 Eye bolt pin	CK35	24CrMo5	A2-70	A2-70
18 Gasket		← S.S. Reinforced graphite (5) →		
19 Packing		← Graphite rings & wiper rings (6) →		
20 Grease nipple		← Steel →		



Adres : Tersane Caddesi Yaprak Çıkmazi No:2 Aydoğdu İş Merkezi Karaköy/İstanbul
Tel: 212 297 57 30 Fax: 212 297 57 33 E-mail : dd@ddvalve.com Web: www.ddvalve.com

GATE VALVES

SÜRGÜLÜ VANA



FIG. N. 1200 - GATE VALVES DIN PN 16 - Face to Face F5

SIZE DN	50	65	80	100	125	150	200	250	300	350	400	450	500	600	700	800	900	1000	1200	1400
L RF/BW	250	270	280	300	325	350	400	450	500	550	600	650	700	800	900	1000	1100	1200	1400	1600
D	165	185	200	220	250	285	340	405	460	520	580	640	715	840	910	1025	1125	1255	1485	1685
V	200	200	225	250	280	300	400	500	500	600	600	600	600	600	1000	1200	1200	1200	1400	1400
H	350	420	500	520	610	620	780	1050	1200	1400	1580	1750	1900	2300	2600	3200	4400	4700	5200	6200
H1	450	495	580	620	720	760	980	1300	1540	1750	1980	2200	2450	3000	3500	4100	5500	5900	6600	7900

FIG. N. 1210 - GATE VALVES DIN PN 25 - PN 40 - Face to Face F5

SIZE DN	50	65	80	100	125	150	200	250	300	350	400	450	500	600	700	800	900	1000	1200	1400
L RF/BW	250	270	280	300	325	350	400	450	500	550	600	650	700	800	900	1000	1100	1200	1400	1600
D	165	185	200	235	270	300	360	425	485	555	620	670	730	845	960	1085	1185	1320	1530	1755
V	200	200	225	250	280	300	400	500	500	600	600	600	600	600	1000	1200	1200	1200	1400	1400
H	400	430	500	520	610	700	900	1050	1200	1400	1580	1750	1900	2300	2600	3200	4400	4700	5200	6200
H1	450	495	580	620	720	840	1100	1300	1540	1750	1980	2200	2450	3000	3500	4100	5500	5900	6600	7900

FIG. N. 1220 - GATE VALVES DIN PN 40 - Face to Face F7

SIZE DN	50	65	80	100	125	150	200	250	300	350	400	450	500	600	700	800	900	1000	--	--
L RF/BW	250	290	310	350	400	450	550	650	750	850	950	1050	1150	1350	1550	1750	1950	2150	--	--
D	165	185	200	235	270	300	375	450	515	580	660	685	755	890	995	1140	1250	1360	--	--
V	200	200	225	250	300	400	500	500	600	700	700	800	1000	1200	1200	1400	1400	1400	--	--
H	400	430	500	520	610	700	900	1050	1200	1400	1580	1750	1900	2300	2600	3200	4400	4700	--	--
H1	450	495	580	620	720	840	1100	1300	1540	1750	1980	2200	2450	3000	3500	4100	5500	5900	--	--

FIG. N. 1230 - GATE VALVES DIN PN 63 - Face to Face F7

SIZE DN	50	65	80	100	125	150	200	250	300	350	400	500	600
L RF/BW	250	290	310	350	400	450	550	650	750	850	950	1150	1350
D	180	205	215	250	295	345	415	470	530	600	670	800	930
V	200	250	250	400	400	500	600	700	700	800	1000	1000	1200
H	450	500	540	670	685	810	970	1155	1330	1500	1680	2100	2400
H1	500	570	620	780	810	980	1180	1420	1660	1880	2100	2650	3100

FIG. N. 1240 - GATE VALVES DIN PN 100 - Face to Face F7

SIZE DN	50	65	80	100	125	150	200	250	300	350	400	500	600
L RF/BW	250	290	310	350	400	450	550	650	750	850	950	1150	1350
D	195	220	230	265	315	355	430	505	585	655	715	870	990
V	200	250	250	400	400	500	600	700	700	800	1000	1000	1200
H	450	500	540	670	685	810	970	1155	1330	1500	1680	2100	2400
H1	500	570	620	780	810	980	1180	1420	1660	1880	2100	2650	3100

FIG. N. 1250 - GATE VALVES DIN PN 160 - Face to Face F8

SIZE DN	50	65	80	100	125	150	200	250	300	350	400	--	--
L RF/BW	300	360	390	450	525	600	750	900	1050	1200	1350	--	--
D	195	220	230	265	315	355	430	505	585	655	715	--	--
V	200	250	250	400	400	500	600	700	700	800	1000	--	--
H	450	500	540	670	685	810	970	1155	1330	1500	1680	--	--
H1	500	570	620	780	810	980	1180	1420	1660	1880	2100	--	--

features on request

- TOP FLANGE TO ISO 5210
- GEAR OPERATOR
- CHAIN WHEEL OPERATOR
- PNEUMATIC ACTUATOR
- HYDRAULIC ACTUATOR
- ELECTRIC ACTUATOR
- POSITION INDICATOR
- LIMIT SWITCHES
- LOCKING / INTERLOCK
- PTFE SOFT SEATS
- STEM PROTECTION
- STEM EXTENSION
- LANTERN RING
- EXTENDED STUFFING BOX
- LIVE LOADED PACKING
- DRAIN PLUG
- BY PASS
- BW ENDS
- ANSI CONNECTIONS

